

# Safety: All Slicer Models

All safety interlocks and E-Stop are double redundant per code.

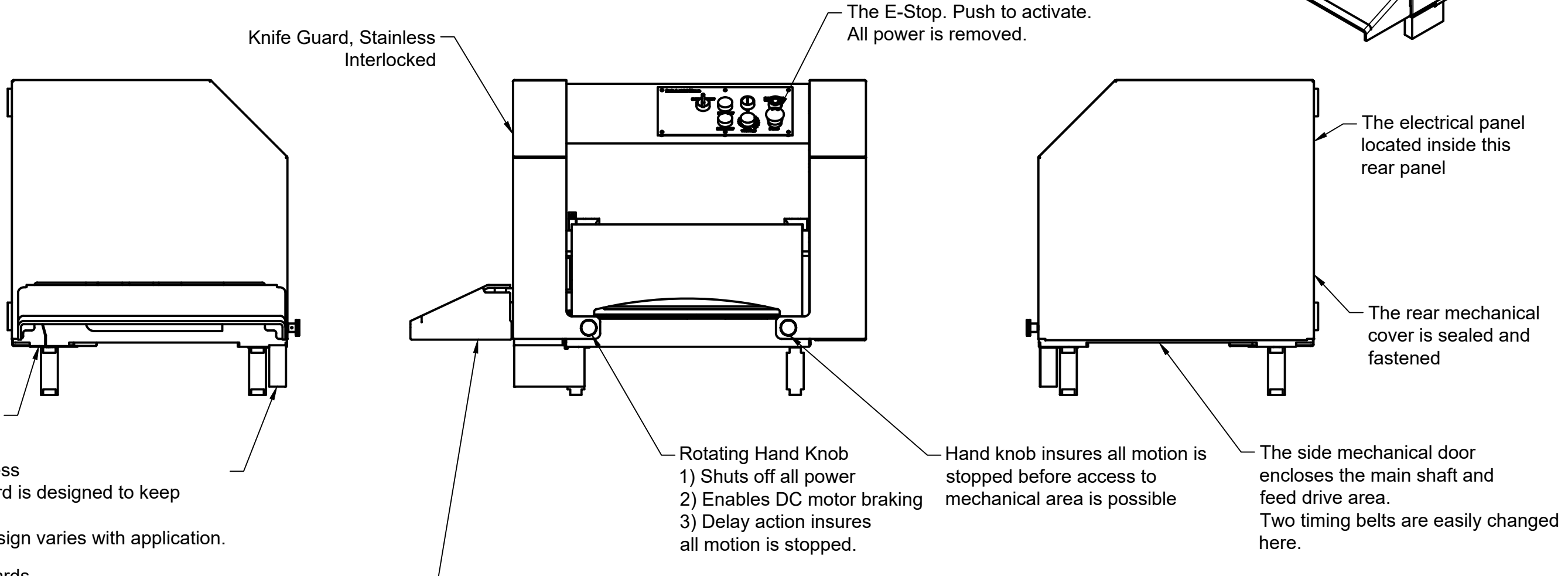
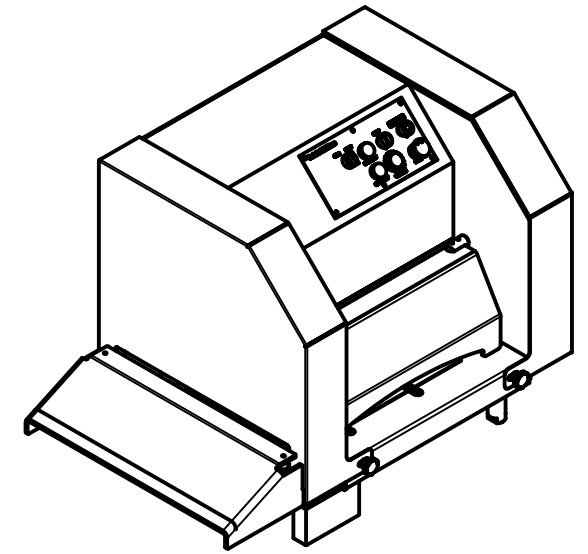

Dx Industrial Slicers Proudly made in the USA	PROJECT <b>40200-DX2000</b>			
	TITLE <b>Safety Features</b>			
APPROVED	SIZE	CODE	DWG NO	REV
CHECKED	B		40200.110	
DRAWN Will Hutter 2/17/2022	SCALE 1:10	WEIGHT	SHEET 1/1	